

**BALL VALVES / Válvulas de bola**  
**TRUNNION**  
**TUBE-SHAPE BODY / Cuerpo en forma de tubo**  
**CLASS / Clase 2500 - PN420**  
**Fig. 5TSR25 REDUCED BORE / Paso reducido**

**BALL**

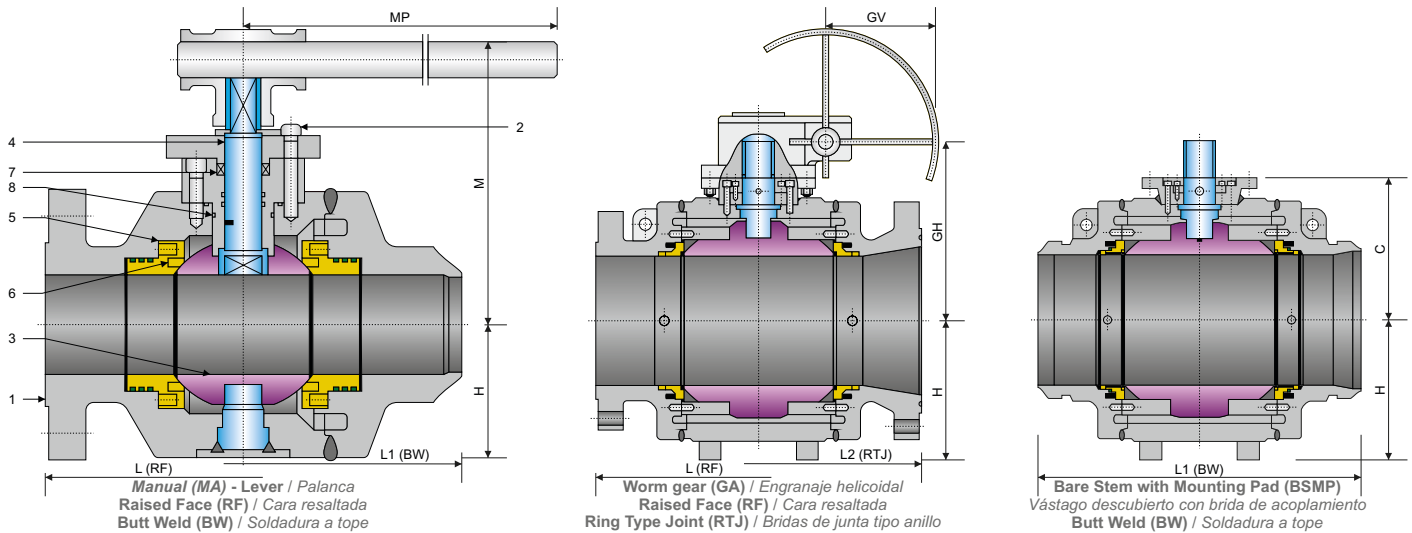

**SPECIFICATIONS / Especificaciones**

**API / ASME**

DESIGN Diseño	FACE TO FACE Cara a cara	CONNECTION END / Extremos		MATERIAL	TEST & CHECK Prueba y Verificación	FIRE TEST Prueba de fuego	SIZES Rango
		FLANGED Bridada	BUTT WELD Soldada a tope				
API 6D	API 6D	ASME B16.5	ASME B16.25	NACE MR0175	API 598	API 6FA API 607	2" x 1 1/2" - 12" x 10"
API 6D	API 6D	MSS SP-44			API 6D		
ASME B16.34	ASME B16.10	ASME B16.47			ASME B16.34		

**MAIN PARTS MATERIAL / Material de las piezas principales**

Nº	PART NAME Nombre de pieza	CARBON STEEL Acero al Carbono	LOW TEMPERATURE STEEL Acero baja temperatura (-40°C)	STAINLESS STEEL Acero Inoxidable
1	Body / Cuerpo	A105	A350 - LF2	A182 - F304 / A182 - F316
2	Stud Nut / Tuerca Espárrago (1)	A193 - B7 / A194 - 2H	A320 - L7 / A194 - 4	A193 - B8 / A194 - 8
2	Stud Nut / Tuerca Espárrago (2)	A193 - B7M / A194 - 2HM	A320 - L7M / A194 - 4	A193 - B8M / A194 - 8M
3	Ball / Bola	A105 + ENP	A350 - LF2 + ENP	A182 - F304 / A182 - F316
4	Stem / Vástago (1)	A276 - 410 / A276 - 420	A350 - LF2 / A276 - 304	A276 - 304 / A276 - 316
4	Stem / Vástago (2)	17 - 4PH	For use at low temperatures resilient steels Usa a bajas temperaturas los aceros elásticos	A276 - 304 / A276 - 316
5	Seat / Asiento	A105 + ENP	A350 - LF2 + ENP	A182 - F304 / A182 - F316
6	Seat insert / Inserto de asiento	Standard: PTFE or Nylon - Special: Peek / Devlon / Viton / Estándar PTFE o Nilón - Especial: Peek / Devlon / Viton		
7	O-Ring	NBR or Viton / NBR o Viton	HNBR or Viton / HNBR o Viton	Viton
8	Gasket / Junta	Graphite + Stainless Steel / Grafito + Acero Inoxidable		

**MAIN EXTERNAL DIMENSIONS / Dimensiones externas principales**

**CLASS 2500 - PN420 (NPS 2" x 1 1/2" - 12" x 10")**

Reduced bore / Paso reducido												
DN (mm.)	NPS (in.)	L (RF)	L1 (BW)	L2 (RTJ)	MA		GA		C	H	W / P (Kg.)	TORQUE(Nm) Esf. torsión
					MH	MP	GH	GV				
50x40	2" x 1 1/2"	451	451	454	155	800	-	-	115	105	63	320
80x50	3" x 2"	578	578	584	168	800	170	350	120	125	158	589
100x80	4" x 3"	673	673	683	205	1000	250	500	175	200	270	1577
150x100	6" x 4"	914	914	927	-	-	290	500	225	230	517	1965
200x150	8" x 6"	1022	1022	1038	-	-	340	600	260	250	1098	5501
250x200	10" x 8"	1270	1270	1292	-	-	470	600	380	340	1667	11786
300x250	12" x 10"	1422	1422	1445	-	-	490	700	450	425	2567	13222

**Notes / Notas:**

- Approximate weights / Pesos aproximados.
- Larger diameters on request / Diámetros superiores bajo petición.
- Other material on request / Otros materiales bajo petición.
- (1) Conventional type / Tipo convencional
- (2) Sulfur resistant / Resistente al azufre

**UNITS / Unidades mm**